

Paasche®

LMS-2-14 DUAL FLUID SPRAY GUN

OPERATING INSTRUCTIONS AND REPLACEMENT PARTS

Applications: Silvering Mirrors, Chroming Dual Material Applications.

WARNING: Spray materials may be harmful if inhaled or allowed to come into contact with skin or eyes. Consult the product label and Material Safety Data Sheet supplied for the spray material. Follow all safety precautions. **CAUTION:** Well Ventilated Area Required to remove fumes, dust or overspray. Check compatibility of materials used with Polyethylene container and PVC Fluid Hose. Secure airhose and fluid hose wrench tight for safety and to prevent leaks.
Maximum Air Pressure 80 P.S.I.
Maximum Fluid Pressure 45 P.S.I.

INTRODUCTION:

This Manual Spray Gun requires clean dry air regulated from 6 to 8 C.F.M. at 45 to 60 lbs. air pressure depending on the size of atomizing heads to be used. Paasche Regulator & Condenser Units are recommended for attaching to air supply line to remove water, oil, rust or scale and help insure a quality finish of coating.

AIR AND FLUID CONNECTIONS:

1. Air Connection: To remove any accumulated foreign matter blow out all hoses before using.
 - a. Air supply to Spray Gun must be turned off before attaching fittings to the Air Inlet.
 - b. Attach HT-1/4 Air Hose to the Air Outlet on the Air Regulator and Air Inlet on the bottom of the handle on the Spray Gun.
2. Fluid Hose: If you use a fluid hose they will need 3/8"NPS female couplings to attach to each spray head.
 - a. Paasche makes the LM-14S stainless steel nut and Nipple if needed. The nut and nipple will attach to the spray heads and you can push your hose onto the nipple. *(See Bottom next page)
3. Fluid Container Connection: When using USP-QT (QT./946 I) Plastic Bottle Assemblies, make sure Screw Covers are tightened securely so fluid will not leak at Bottle connections.
4. Tighten all Air and Fluid connections securely.

OPERATION:

1. After hose connections have been made, regulate the air pressure to about 45 lbs. and then pull trigger back slowly.
 - a. The first 1/4" of trigger stroke opens the Air Valve which operates both the cylinders.
 - b. Continued pull on the trigger opens both of the atomizing Spray Heads for spraying.
2. The U-3670 Adjusting Knob (part# 25) can be used to regulate desired amount of fluid to the automatic Spray Head. Tighten H-153 (#27) to lock setting
3. Dual Fluid Spray Guns are designed to atomize and mix fluid materials outside the atomizing aircaps. This prevents materials from hardening inside the spray gun.
4. The U-3687 PTFE Packing Assembly (part# 19) should be replaced periodically.



Paasche Airbrush Company
9511 58th Place Kenosha, WI 53144
Phone: 773-867-9191 • Fax: 773-867-9198
Website: paascheairbrush.com
E-Mail: info@paascheairbrush.com

1. BSR-15-0	Standard Stainless Aircap(.055)	17. U-3557	St. St. Fluid Body - RIGHT
2. BUS-12	Stainless Aircap Nut	18. U-3558	St. St. Fluid Body - LEFT
3. U-0	Standard Stainless Tip(.055)	19. U-3687	PTFE Packing Assembly (2)
4. U-3675	Hook	20. U-2493	Cylinder Shell Assembly
6. U-3674	Tee Adapter	21. U-3677	Needle
7. U-3676	Set Screw (2)	22. U-3664	PTFE Piston Assembly
8. U-3678	Plug (Nylon)	23. U-2500	Spring
9. U-3679	Gasket (PTFE)	24. U-3669	Rear Cap
10. AN	Nylon Washer	25. U-3670	Needle Stop Adjustment Knob
11. LM-4	Nut (Gold Anodized)	26. USP-QT	(QT./946 I) Plastic bottle Assembly
12. MT-21	O-Ring	27. H-153	Set Screw

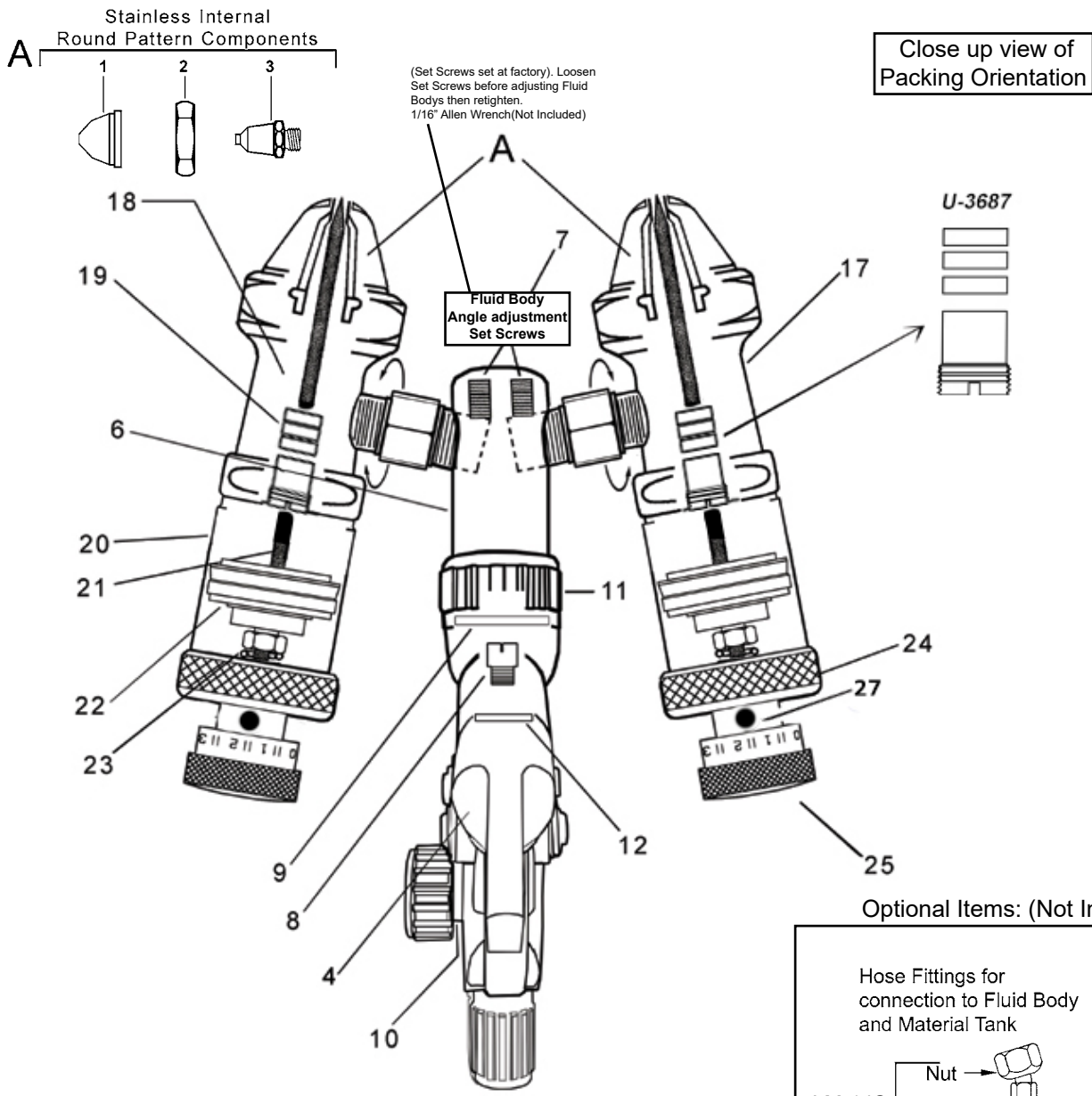

SAFETY PRECAUTIONS

This manual contains information that is important for you to know and understand. This information relates to USER SAFETY and PREVENTING EQUIPMENT PROBLEMS. To help you recognize this information, we use the following symbols. Please pay particular attention to these sections.

WARNING

CAUTION

NOTE





Important safety information - A hazard that may cause serious injury or loss of life.

Important information that tells how to prevent damage to equipment, or how to avoid a situation that may cause minor injury.

Information that you should pay special attention to.

WARNING

**The following hazards may occur during the normal use of this equipment.
Please read the following chart before using this equipment.**

HAZARD	CAUSE	SAFEGUARDS
Fire 	Solvent and coatings can be highly flammable or combustible especially when sprayed.	Adequate exhaust must be provided to keep air free of accumulations of flammable vapors. Smoking must never be allowed in the spray area. Fire extinguishing equipment must be present in the spray area.
Solvent Spray 	During use and while cleaning and flushing, solvents can be forcefully expelled from fluid and air passages. Some solvents can cause eye injury.	Wear eye protection.
Inhaling Toxic Substances 	Certain materials may be harmful if inhaled, or if there is contact with the skin.	Follow the requirements of the Material Safety Data Sheet supplied by your coating material manufacturer. Adequate exhaust must be provided to keep the air free of accumulations of toxic materials. Use a mask or respirator whenever there is a chance of inhaling sprayed materials. The mask must be compatible with the material being sprayed and its concentration. Equipment must be as prescribed by an industrial hygienist or safety expert, and be NIOSH approved.
Explosion Hazard - Incompatible Materials 	Halogenated hydrocarbon solvents - for example: methylene chloride and 1,1,1, - Trichloroethane are not chemically compatible with the aluminum that might be used in many system components. The chemical reaction caused by these solvents reacting with aluminum can become violent and lead to an equipment explosion.	Guns with stainless steel internal passageways may be used with these solvents. However, aluminum is widely used in other spray application equipment - such as material pumps, regulators, valves, and cups. Check all equipment items before use and make sure they can also be used safely with these solvents. Read the label or data sheet for the material you intend to spray. If in doubt as to whether or not a coating or cleaning material is compatible, contact your material supplier.
General Safety	Improper operation or maintenance of equipment.	Operators should be given adequate training in the safe use and maintenance of the equipment (in accordance with the requirements of NFPA-33, Chapter 15). Users must comply with all local and national codes of practice and insurance company requirements governing ventilation, fire precautions, operation, maintenance, and housekeeping. These are OSHA Sections 1910.94 and 1910.107 and NFPA-33.
Cumulative Trauma Disorders ("CTD's") CTD's, or musculoskeletal disorders, involve damage to the hands, wrists, elbows, shoulders, neck, and back. Carpal tunnel syndrome and tendonitis (such as tennis elbow or rotator cuff syndrome) are examples of CTD's.	Use of hand tools may cause cumulative trauma disorders ("CTD's"). CTD's, when using hand tools, tend to affect the upper extremities. Factors which may increase the risk of developing a CTD include: <ol style="list-style-type: none"> 1. High frequency of the activity. 2. Excessive force, such as gripping, pinching, or pressing with the hands and fingers. 3. Extreme or awkward finger, wrist, or arm positions. 4. Excessive duration of the activity. 5. Tool vibration. 6. Repeated pressure on a body part. 7. Working in cold temperatures. CTD's can also be caused by such activities as sewing, golf, tennis, and bowling, to name a few.	Pain, tingling, or numbness in the shoulder, forearm, wrist, hands, or fingers, especially during the night, may be early symptoms of a CTD. Do not ignore them. Should you experience any such symptoms, see a physician immediately. Other early symptoms may include vague discomfort in the hand, loss of manual dexterity, and nonspecific pain in the arm. Ignoring early symptoms and continued repetitive use of the arm, wrist, and hand can lead to serious disability. Risk is reduced by avoiding or lessening factors 1-7.

